



TIEMME

SERVOCOMANDO Drive

Art. 9535 (per art. 2138 e per art. 2133)

SERVOCOMANDO PER VALVOLE DI ZONA

Il servocomando opera sulla valvola con una rotazione monodirezionale di 90° passando dalla posizione di apertura alla posizione di chiusura e viceversa

DRIVE FOR ZONE BALL VALVE

The drive works on the valve with a 90° mono-directional rotation by moving from the closing position to the opening position and viceversa.

Schema elettrico Electrical diagram

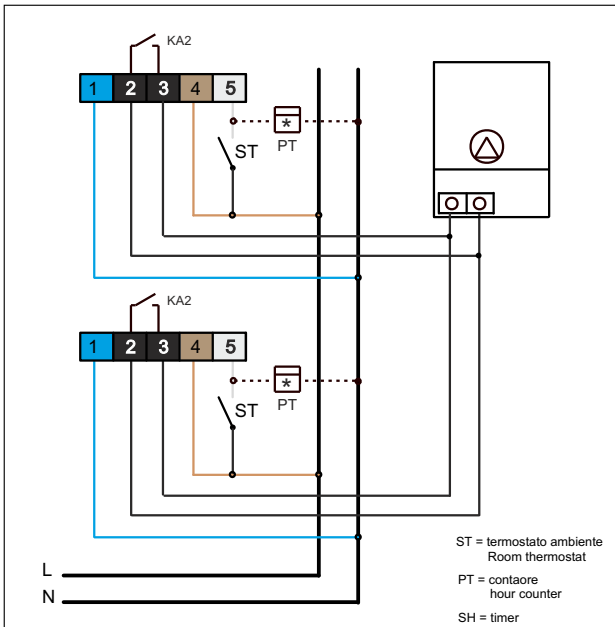

- 1 - BLU/BLEU -----NEUTRO, NEUTRAL
- 2 - NERO/BLACK -----CONSENSO CALDAIA, BOILER
- 3 - NERO/BLACK -----CONSENSO CALDAIA, BOILER
- 4 - MARRONE/BROWN -----FASE, PHASE
- 5 - GRIGIO/GREY -----THERMOSTATO AMBIENTE, ROOM THERMOSTAT

Dimensioni d'ingombro External dimension

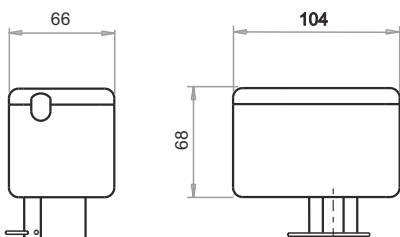

Art. 9535R050607 (230Vac) Caratteristiche Tecniche Technical Features

Alimentazione morsetti 1 - 4: a 230Vac o 24Vac(50...60 Hz)
Power supply terminals 1 -4:at 230Vac or 24Vac (50...60Hz)

Potenza assorbita 6 VA
Absorbed power 6 VA

Contatto relè morsetti 2 -3: pulito (non in tensione) attivo a
Contact relay terminals 2 -3: dry (no power) close when the
valve is open

Grado di protezione IP 44
Protection degree class IP 44

Temperatura di esercizio min -5°C max 55°C
Operating temperature min -5°C max 55°C

Coppia max di rotazione 8 Nm
Maximum rotation couple 8 Nm

Tempo di manovra 40 sec.
Control time 40 sec.

Fusibile 5x20 F350 mA.
Fusing 5x20 F350 mA.

*Verificare che l'alimentazione corrisponda a quella prevista dalle caratteristiche.

*Make sure that the power supply is corresponding to that foreseen by technical characteristics.

*Trattandosi di un apparecchio di classe II non si deve effettuare il collegamento al conduttore di protezione.

*Because it is a class II unit it is not necessary to connect it to a protection conductor.

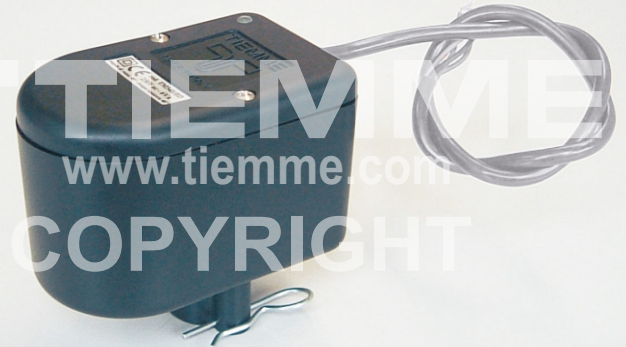

TIEMME Raccorderie S.p.A. si riserva di apportare modifiche in qualsiasi momento senza preavviso.
TIEMME Raccorderie S.p.A. reserves the right to modify contents in any time without prior advise.
È vietata qualsiasi forma di riproduzione, se non autorizzata.
is forbidden any reproduction unless under TIEMME authorization



TIEMME Raccorderie S.p.A.
Via Cavallera 6/A (Loc. Barco) - 25045 Castegnato (Bs) - Italy
Tel +39 030 2142211 R.A. - Fax +39 030 2142206
info@tiemme.com - www.tiemme.com
©TIEMME Raccorderie S.p.A. 9535 Rev. B. 10-11

